

# 31 TRENCHING

## Contents

- Background
- Soil types
- Causes of cave-ins
- Protection against cave-ins
- Other hazards and safeguards
- Emergency procedures

## Background

### Fatalities

A significant number of deaths and injuries in sewer and watermain work are directly related to trenching.

Trenching fatalities are mainly caused by cave-ins. Death occurs by suffocation or crushing when a worker is buried by falling soil.

Over half of all powerline contacts involve buried cable. Before excavating, the gas, electrical, and other services in the area must be accurately located and marked. If the service poses a hazard, it must be shut off and disconnected.

### Injuries

The following are the main causes of lost-time injuries in the sewer and watermain industry:

- materials and equipment falling into the trench
- slips and falls as workers climb on and off equipment
- unloading pipe
- handling and placing frames and covers for manholes and catch basins
- handling and placing pipe and other materials
- being struck by moving equipment
- falls as workers climb in or out of an excavation

- falling over equipment or excavated material
- falling into the trench
- exposure to toxic, irritating, or flammable gases.

Many of these injuries are directly related to trenching.

### Regulations

Supervisors and workers in the sewer and watermain industry must be familiar with the “Excavations” section of the Construction Regulation,

It is important to understand, for instance, the terms “trench” and “excavation.” An excavation is a hole left in the ground as the result of removing material. A trench is an excavation in which the depth exceeds the width (Figure 1).

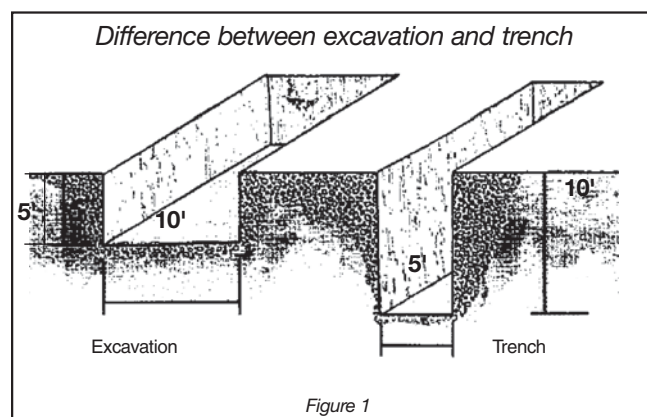

The “Excavations” section of the Construction Regulation identifies the various types of soils and specifies the type of shoring and timbering to be used for each. It also spells out the requirements for trench support systems that must be designed by a professional engineer.

## Soil types

The type of soil determines the strength and stability of trench walls.

Identifying soil types requires knowledge, skill, and experience. Even hard soil may contain faults in seams or layers that make it unstable when excavated.

The foreman or supervisor must be knowledgeable about soil types found on a project and plan protection accordingly. This knowledge must include an awareness that soil types and conditions can change over very short distances. It is not unusual for soil to change completely within 50 metres or for soil to become saturated with moisture over even smaller distances.

The Construction Regulation sets out four soil types. If you are unsure about the soil type, have the soil tested to confirm the type.

**Type 1** — It is hard to drive a pick into Type 1 soil. Hence, it is often described as “hard ground to dig”. In fact, the material is so hard, it is close to rock.

When excavated, the sides of the excavation appear smooth and shiny. The sides will remain vertical with no water released from the trench wall.

If exposed to sunlight for several days, the walls of Type 1 soil will lose their shiny appearance but remain intact without cracking and crumbling.

If exposed to rain or wet weather, Type 1 soil may break down along the edges of the excavation.

Typical Type 1 soils include “hardpan,” consolidated clay, and some glacial tills.

**Type 2** — A pick can be driven into Type 2 soil relatively easily. It can easily be excavated by a backhoe or hand-excavated with some difficulty.

In Type 2 soil, the sides of a trench will remain vertical for a short period of time (perhaps several hours) with no apparent tension cracks. However, if the walls are left exposed to air and sunlight, tension cracks will appear as the soil starts to dry. The soil will begin cracking and splaying into the trench.

Typical Type 2 soils are silty clay and less dense tills.

**Type 3** — Much of the Type 3 soil encountered in construction is previously excavated material. Type 3 soil can be excavated without difficulty using a hydraulic backhoe.

When dry, Type 3 soil will flow through fingers and form a conical pile on the ground. Dry Type 3 soil will not stand vertically and the sides of the excavation will cave in to a natural slope of about 1 to 1 depending on moisture.

Wet Type 3 soil will yield water when vibrated by hand. When wet, this soil will stand vertically for a short period. It dries quickly, however, with the vibration during excavation causing chunks or solid slabs to slide into the trench.

All backfilled or previously disturbed material should be treated as Type 3. Other typical Type 3 soil includes sand, granular materials, and silty or wet clays.

**Type 4** — Type 4 soil can be excavated with no difficulty using a hydraulic backhoe. The material will flow very easily and must be supported and contained to be excavated to any significant depth.

With its high moisture content, Type 4 soil is very sensitive to vibration and other disturbances which cause the material to flow.

Typical Type 4 material includes muskeg or other organic deposits with high moisture content, quicksand, silty clays with high moisture content, and leta clays. Leta clays are very sensitive to disturbance of any kind.

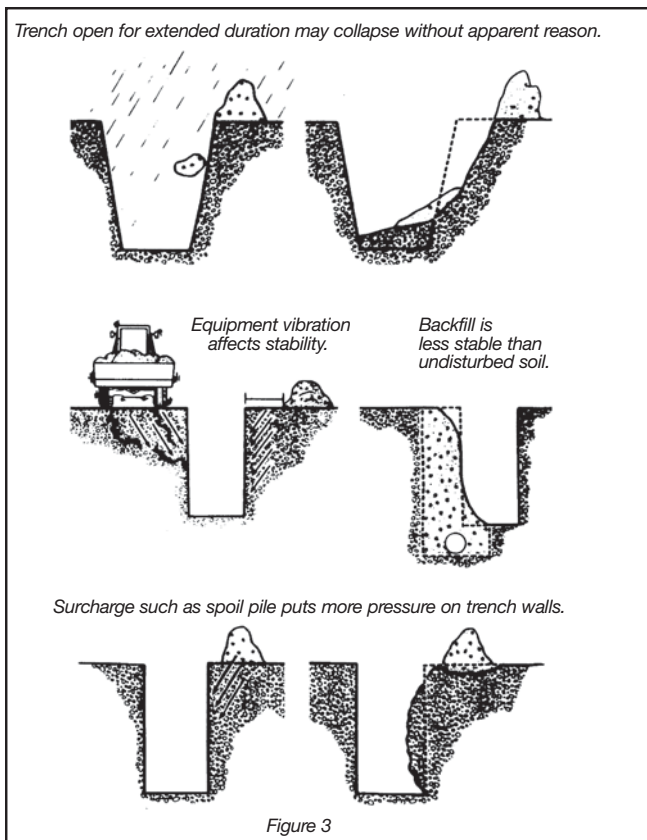

Many factors such as cracks, water, vibration, weather, and previous excavation can affect trench stability (Figure 2). Time is also a critical factor. Some trenches will remain open for a long period, then suddenly collapse for no apparent reason.

Figure 3 shows the typical causes of cave-ins.

The main factors affecting trench stability are soil type, moisture, vibration, surcharge, previous excavation, existing foundations, and weather.

**Moisture content**

The amount of moisture in the soil has a great effect on soil strength.

Once a trench is dug, the sides of the open excavation are exposed to the air. Moisture content of the soil begins to change almost immediately and the strength of the walls may be affected.

The longer an excavation is open to the air, the greater the risk of a cave-in.

**Causes of Cave-Ins**

Soil properties often vary widely from the top to the bottom and along the length of a trench.

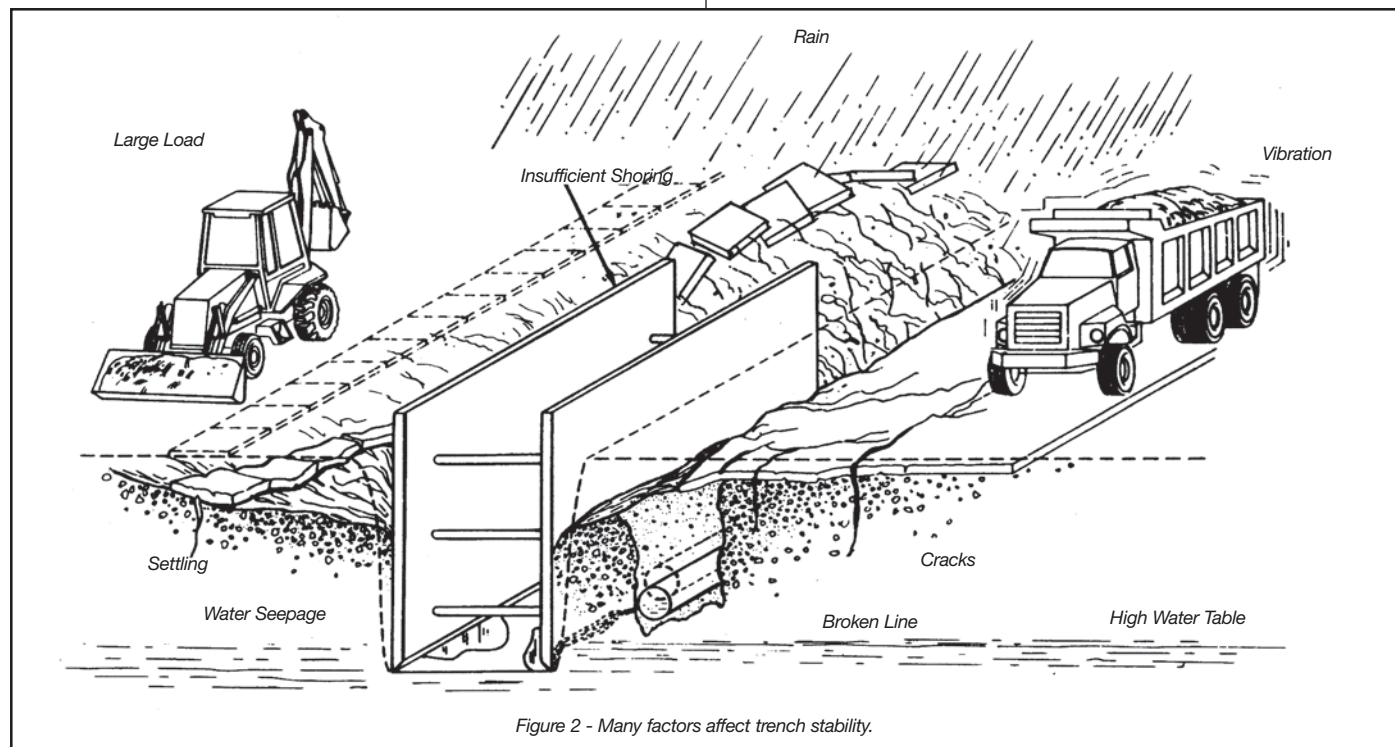

**Vibration**

Vibration from various sources can affect trench stability.

Often trench walls are subject to vibration from vehicular traffic or from construction operations such as earth moving, compaction, pile driving, and blasting. These can all contribute to the collapse of trench walls.

**Surcharge**

A surcharge is an excessive load or weight that can affect trench stability.

For instance, excavated soil piled next to the trench can exert pressure on the walls. Placement of spoil piles is therefore important. Spoil should be kept as far as is practical from the edge of the trench. Mobile equipment and other material stored close to the trench also add a surcharge that will affect trench stability.

One metre from the edge to the toe of the spoil pile is the minimum distance requirement (Figure 4). The distance should be greater for deeper trenches.

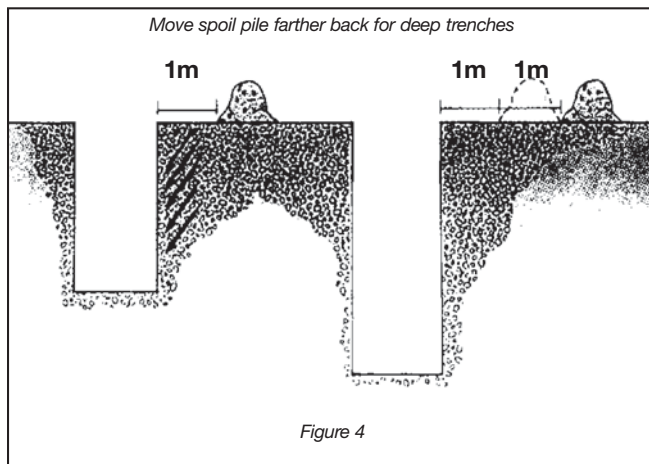

Figure 4

**Previous excavation**

Old utility trenches either crossing or running parallel to the new trench can affect the strength and stability (Figure 5).

Soil around and between these old excavations can be very unstable. At best it is considered Type 3 soil — loose, soft, and low in internal

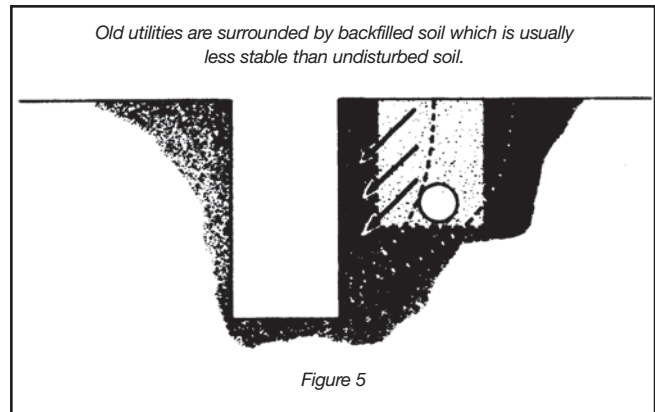

Figure 5

strength. In some unusual circumstances it may be Type 4 — wet, muddy, and unable to support itself.

This kind of soil will not stand up unless it is sloped or shored.

**Existing foundations**

Around most trenches and excavations there is a failure zone where surcharges, changes in soil condition, or other disruptions can cause collapse.

When the foundation of a building adjacent to the trench or excavation extends into this failure zone, the result can be a cave-in (Figure 6). Soil in this situation is usually considered Type 3.

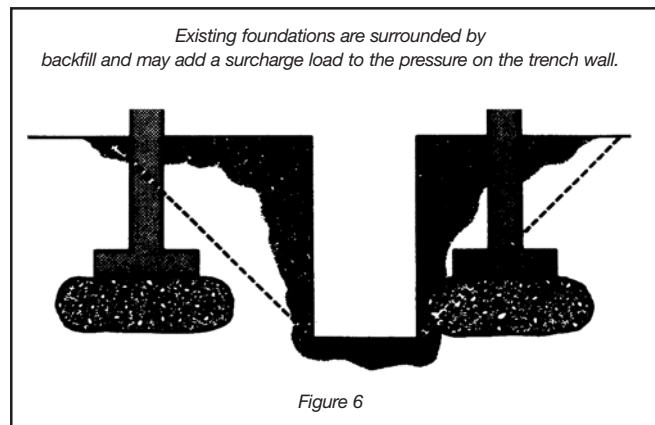
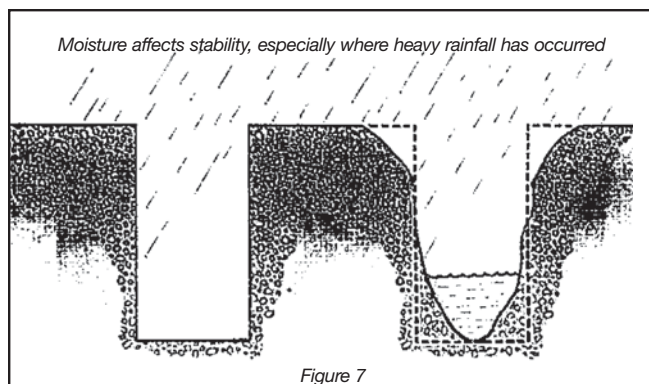

Figure 6

**Weather**

Rain, melting snow, thawing earth, and overflow from adjacent streams, storm drains, and sewers all produce changes in soil conditions. In fact, water from any source can reduce soil cohesion (Figure 7).



Frozen soil does not mean that you can have reduced shoring or that a heavier load can be supported. Frost extends to a limited depth only.

## Protection Against Cave-Ins

There are three basic methods of protecting workers against trench cave-ins:

- sloping
- trench boxes
- shoring

Most fatal cave-ins occur on small jobs of short duration such as service connections and excavations for drains and wells. Too often people think that these jobs are not hazardous enough to require safeguards against collapse.

Unless the walls are solid rock, never enter a trench deeper than 1.2 metres (4 feet) if it is not properly sloped, shored, or protected by a trench box.

### Sloping

One way to ensure that a trench will not collapse is to slope the walls.

Where space and other requirements permit sloping, the angle of slope depends on soil conditions (Figures 8, 9 and 10).

For Type 1 and 2 soils, cut trench walls back at an angle of 1 to 1 (45 degrees). That's one metre back for each metre up. Walls should be sloped to within 1.2 metres (4 feet) of the trench bottom (Figure 8).

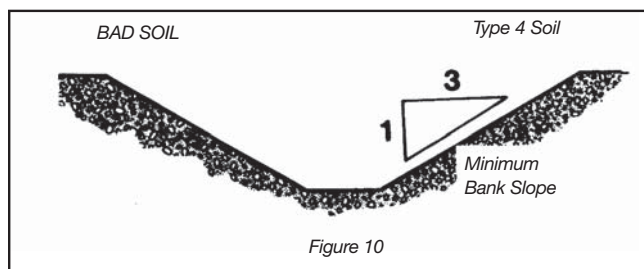
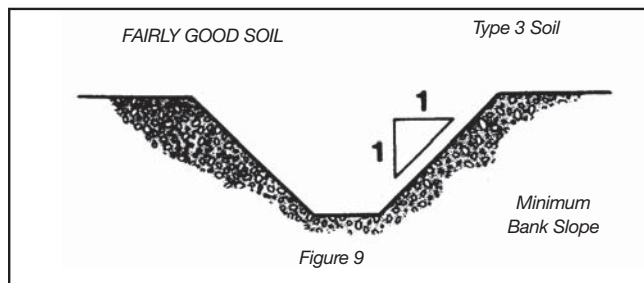
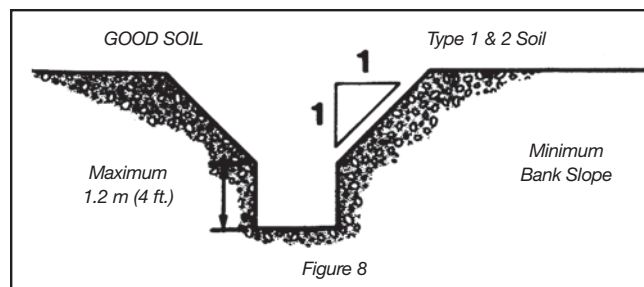

For Type 3 soil, cut walls back at a gradient of 1 to 1 from the trench bottom (Figure 9).

For Type 4 soil, slope the walls at 1 to 3. That's 3 metres back for every 1 metre up from the trench bottom (Figure 10).

Although sloping can reduce the risk of a cave-in, the angle must be sufficient to prevent spoil not only from sliding back but also from exerting too much pressure on the trench wall (Figure 11).

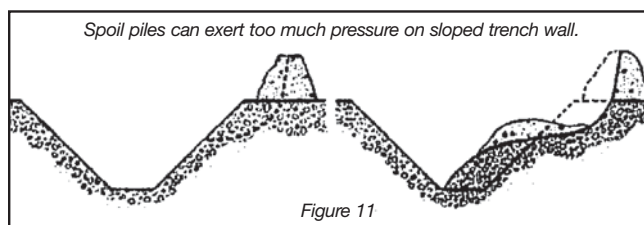

Sloping is commonly used with shoring or trench boxes to cut back any soil above the protected zone. It is also good practice to cut a bench at the top of the shoring or trench (Figure 12).

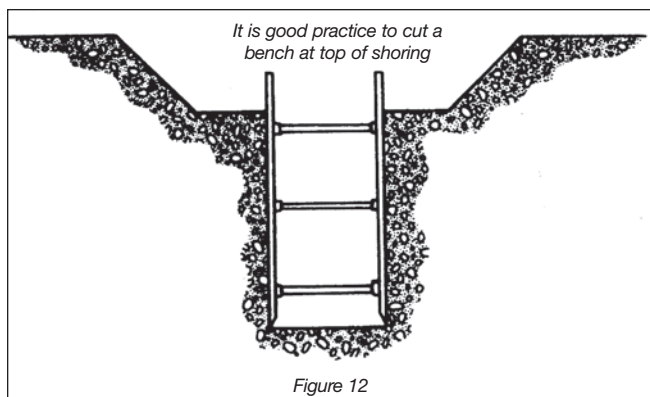

If sloping is to be used above a trench box, the top portion of the cut should first be sloped 1 to 1 (or 1 to 3 for Type 4 soil — see previous page). Then the box should be lowered into the trench (Figure 13).

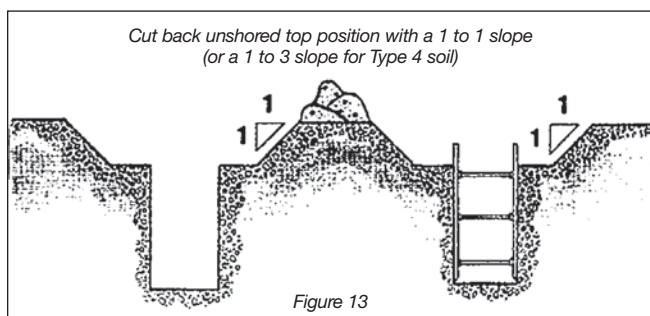

**Trench boxes**

Trench boxes are not usually intended to shore up or otherwise support trench walls. They are meant to protect workers in case of a cave-in.

Design drawings and specifications for trench boxes must be signed and sealed by the professional engineer who designed the system and must be kept on site by the constructor.

Boxes are normally placed in an excavated but unshored trench and used to protect personnel. A properly designed trench box is capable of withstanding the maximum lateral load expected at a given depth in a particular soil condition.

Trenches near utilities, streets, and buildings may require a shoring system.

As long as workers are in the trench they should remain inside the box. Workers must not be inside the trench or the box when the box is being moved. A ladder must be set up in the trench box at all times.

Excavation should be done so that the space between the trench box and the excavation is minimized (Figure 14).

The two reasons for this are

- 1) allowing closer access to the top of the box
- 2) limiting soil movement in case of a cave-in.

Check the drawings and specifications for the trench box to see if the space between the box and the trench wall needs to be backfilled and the soil compacted.

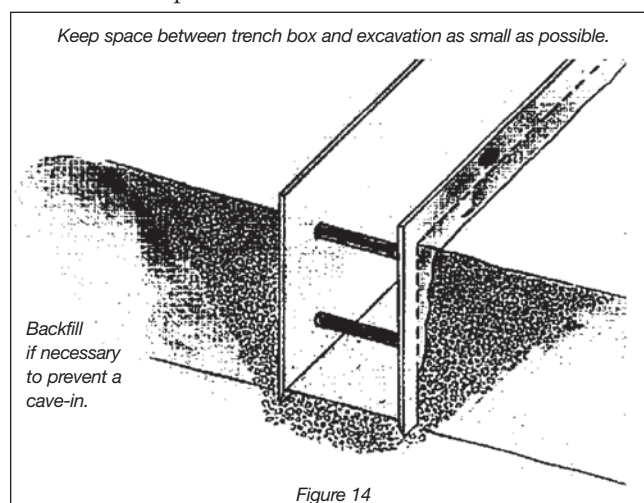

**Shoring**

Shoring is a system which “shores” up or supports trench walls to prevent movement of soil, underground utilities, roadways, and foundations.

Shoring should not be confused with trench boxes. A trench box provides worker safety but gives little or no support to trench walls or existing structures such as foundations and manholes.

The two types of shoring most commonly used are timber and hydraulic. Both consist of posts, wales, struts, and sheathing.

Figures 15 and 16 identify components, dimensions, and other requirements for timber shoring in some typical trenches.

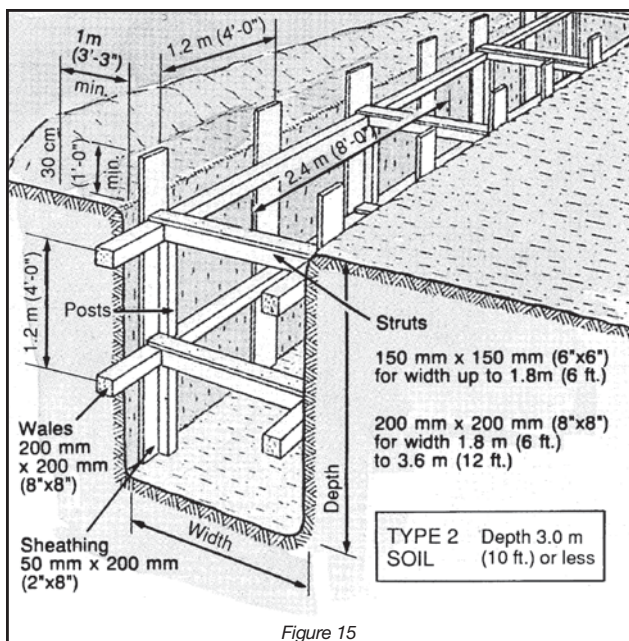

Figure 15

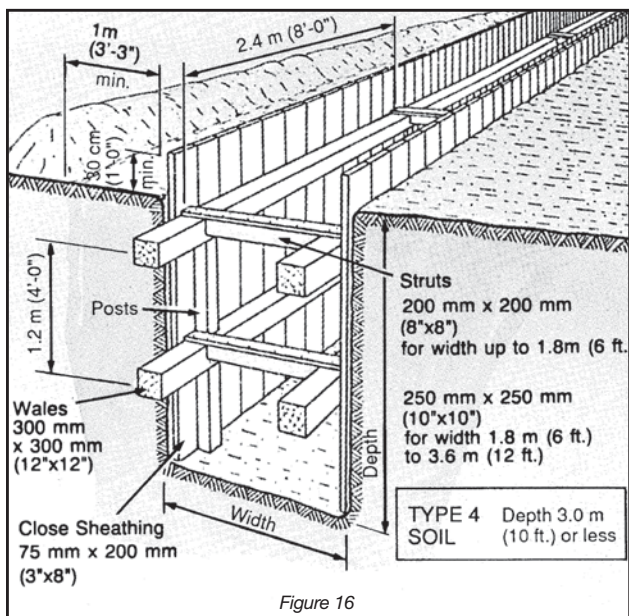

Figure 16

“Hydraulic shoring” refers to prefabricated strut and/or wale systems in aluminum or steel. Strictly speaking, these may not operate hydraulically. Some are air-operated or manually jacked. Design drawings and specifications for prefabricated shoring systems must be kept on site.

One major advantage of hydraulic shoring over some applications of timber shoring is safety during installation. Workers do not have to enter the trench to install the system. Installation can be done from the top of the trench.

Most hydraulic systems are

- light enough to be installed by one worker
- gauge-regulated to ensure even distribution of pressure along the trench line
- able to “pre-load” trench walls, thereby using the soil’s natural cohesion to prevent movement.
- easily adapted to suit various trench depths and widths.

Wherever possible, shoring should be installed as excavation proceeds. If there is a delay between digging and shoring, no one must be allowed to enter the unprotected trench.

All shoring should be installed from the top down and removed from the bottom up.

### Access/egress

Whether protected by sloping, boxes, or shoring, trenches must be provided with ladders so that workers can enter and exit safely (Figure 17).

Ladders must

- be placed within the area protected by the shoring or trench box
- be securely tied off at the top
- extend above the shoring or box by at least 1 metre (3 feet)

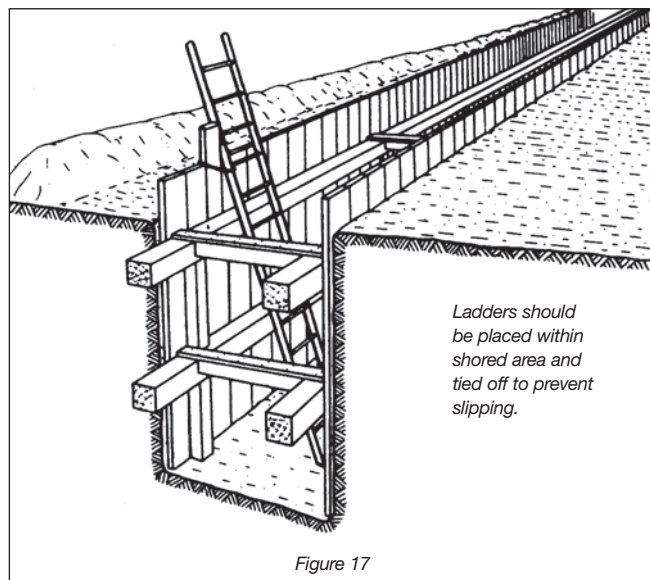

Ladders should be placed within shored area and tied off to prevent slipping.

Figure 17

- be inspected regularly for damage.

Ladders should be placed as close as possible to the area where personnel are working and never more than 7.5 metres (25 feet) away.

Anyone climbing up or down must always face the ladder and maintain 3-point contact. This means that two hands and one foot or two feet and one hand must be on the ladder at all times.

Maintaining 3-point contact also means hands must be free for climbing. Tools and materials should not be carried up or down ladders. Pumps, small compactors, and other equipment should be lifted and lowered by methods that prevent injury from overexertion and falling objects.

**Inspection**

Inspection is everyone's responsibility. Whatever the protective system, it should be inspected regularly.

Check hydraulic shoring for leaks in hoses and cylinders, bent bases, broken or cracked nipples, and other damaged or defective parts (Figure 18).

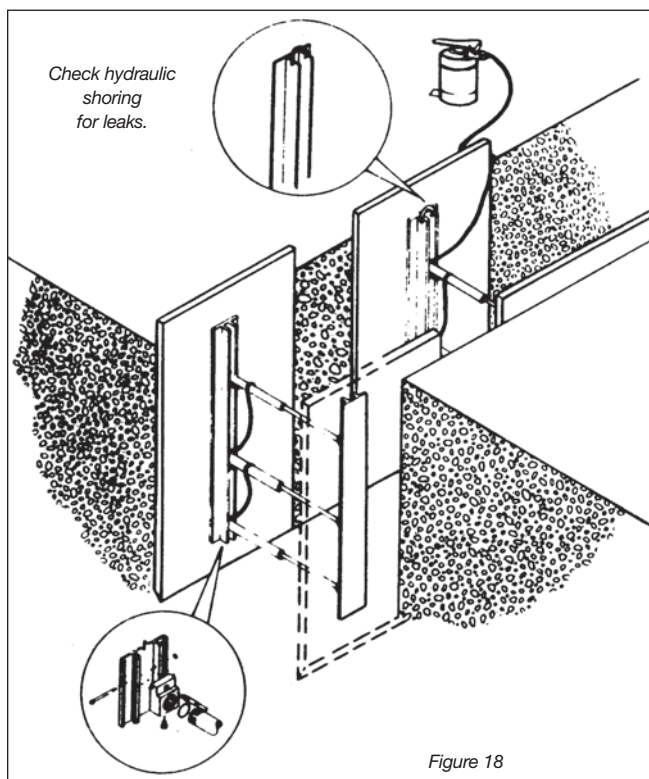

Check timber shoring before installation. Discard damaged or defective lumber. After installation, inspect wales for signs of crushing. Crushing indicates structural inadequacy and calls for more struts (Figure 19).

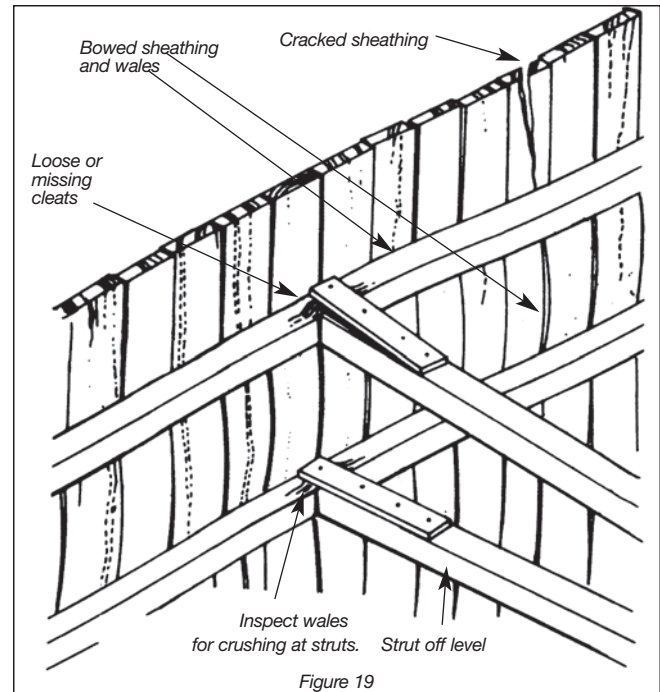

Inspect trench boxes for structural damage, cracks in welds, and other defects (Figure 20). During use, check the box regularly and often to make sure that it is not shifting or settling much more on one side than the other. If it is, leave the trench and ask the supervisor to check for stability.

Check ground surface for tension cracks which may develop parallel to the trench at a distance one-half to three-quarters of the trench depth (Figure 21). If cracks are detected, alert the crew and check all protective systems carefully.

Check areas adjacent to shoring where water may have entered the trench. A combination of water flow and granular soils can lead to undermining of the trench wall. Such conditions have caused fatalities.

Finally, make sure that tools, equipment, material, and spoil are kept at least 1 metre (3 feet) back from the edge of the trench to prevent falling objects from striking workers.



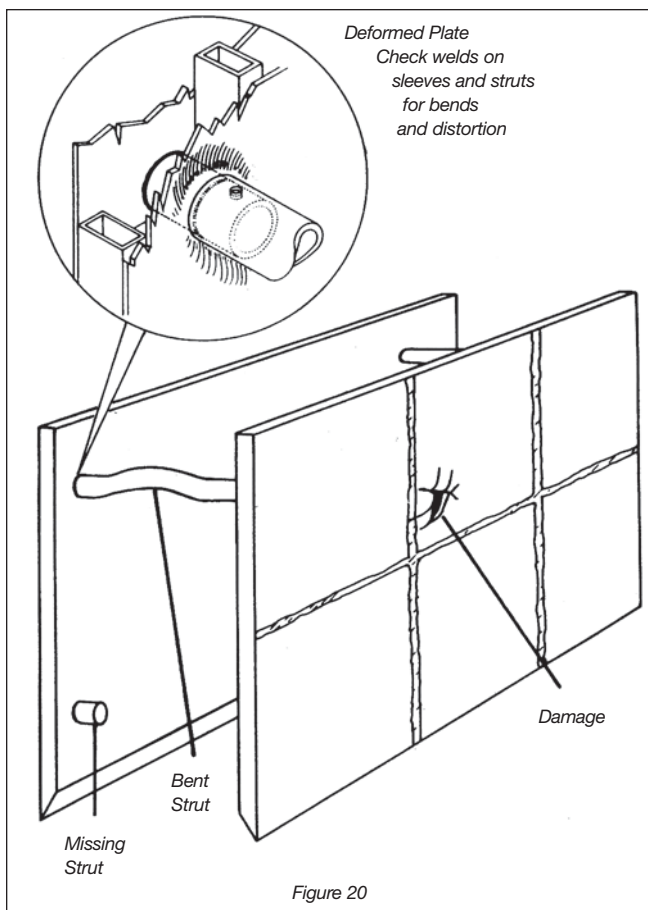

Figure 20

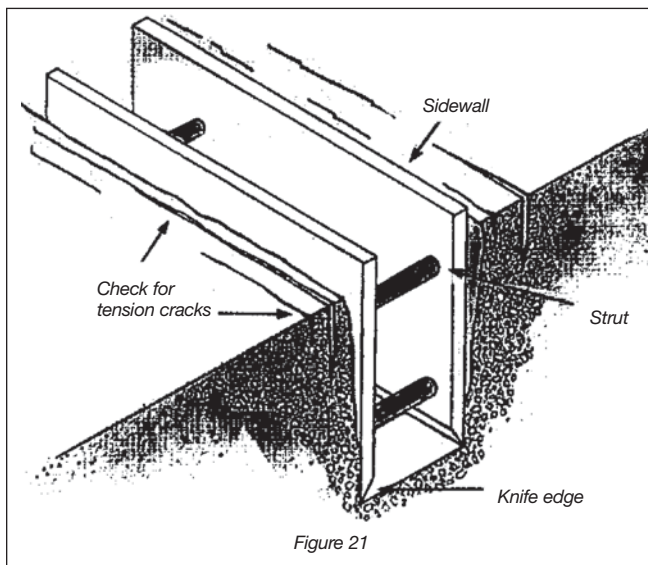

Figure 21

### Summary

Sloping, trench boxes, and shoring are meant to protect workers from the hazards of cave-ins.

The method chosen must meet the specific requirements of the job at hand. Depending on application, one method may be better suited to certain conditions than another.

Whatever the system, inspect it regularly to make sure that it remains sound and reliable.

Remember: Never enter a trench more than 1.2 metres (4 feet) deep unless it is sloped, shored, or protected by a trench box.

## Other Hazards and Safeguards

The risk of a cave-in is not the only hazard in trenching. Injuries and deaths are also related to six other major areas:

- personal protective equipment
- utilities underground and overhead
- materials handling and housekeeping
- heavy equipment
- traffic control
- confined spaces.

### Personal protective equipment

Personal protective equipment is an important defence against certain types of injury.

Injuries from falling and flying objects, for instance, can be reduced by wearing hard hats and eye protection.

Everyone on a construction project must wear Grade 1 safety boots certified by the Canadian Standards Association (CSA) as indicated by the CSA logo on a green triangular patch (Figure 22).

Under the wet, muddy conditions often encountered in trenching, you may also require rubber safety boots displaying the same CSA logo on a green triangular patch.

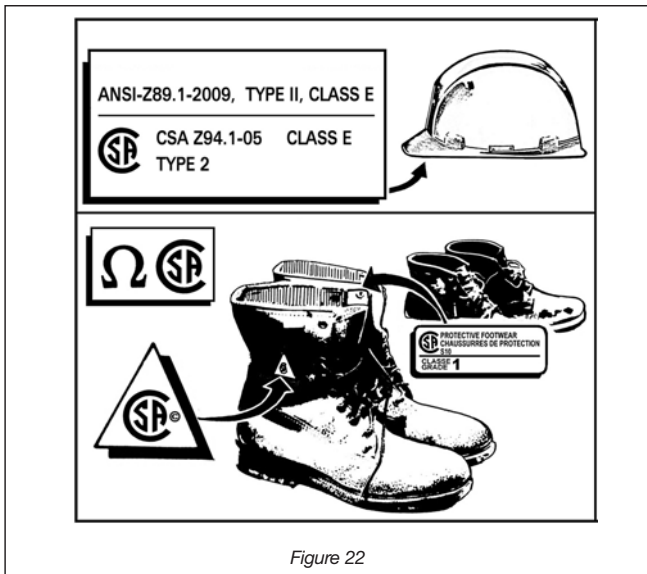

It is mandatory for everyone on a construction project to wear head protection in the form of a hard hat that complies with the current Construction Regulation.

Eye protection is strongly recommended to prevent injuries from construction operations such as chipping and drilling and site conditions such as dust.

Personnel exposed for long periods to noisy equipment should wear hearing protection.

Work in confined spaces such as manholes and valve chambers may require respiratory protection against hazardous atmospheres. See the chapter on Confined Spaces in this manual for more information.

See the chapters on personal protective equipment in this manual for more information.

**Underground utilities**

**Locates** — Services such as gas, electrical, telephone, and water lines must be located by the utility before excavation begins.

Request locates for all the underground utilities in the area where excavation will be taking place. The contractor responsible for the work must contact the owners of any underground utilities that may be in that location or phone Ontario One Call (1-800-400-2255). Some

utilities are not part of the Ontario One Call system. Contact those utilities separately for locate requests.

The service locate provided by the utility owner should indicate, using labelled stakes, flags, and/or paint marks, the centre line of the underground utility in the vicinity of the proposed excavation.

The excavator should not work outside of the area covered by the locate stakeout information without obtaining an additional stakeout.

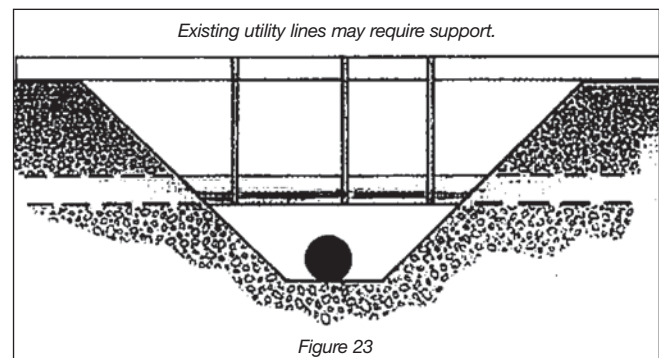

Locate stakeout accuracy should be considered to be 1 metre on either side of the surface centre line locate unless the locate instructions specifically indicate other boundary limits.

Where the underground utility cannot be located within the locate stakeout limits, the utility owner should be contacted to assist with the locate.

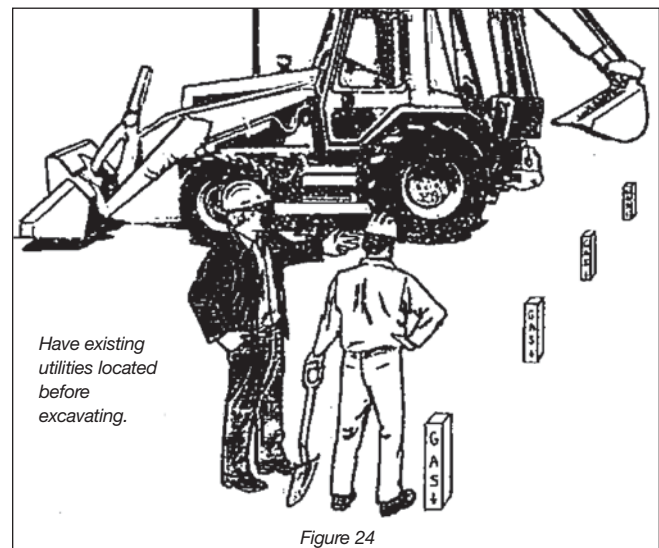

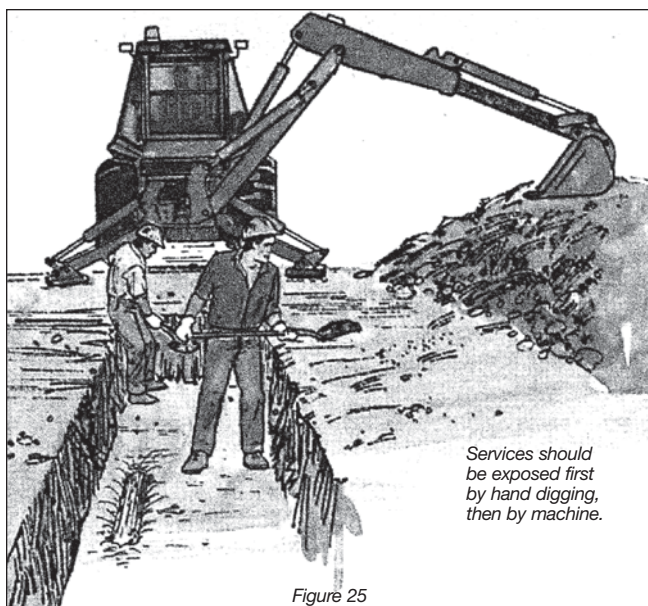

Mechanical excavation equipment should not be used within the boundary limits of the locate without first digging a hole or holes using the procedure below to determine the underground utility's exact centre line and elevation.

Test holes should, in general, be excavated by one of the following methods:

- (a) machine excavation immediately outside the boundary limits and then hand digging laterally until the underground utility is found; or
- (b)
  - (i) hand excavation perpendicular to the centre line of the locate in cuts of at least 1 foot in depth;
  - (ii) mechanical equipment can then be used carefully to widen the hand-dug trench to within one foot of the depth of the hand-dug excavation;
  - (iii) repeat steps (i) and (ii) until the utility is located; or
- (c) a hydro-excavation system — acceptable to the owner of the utility — which uses high-pressure water to break up the cover material and a vacuum system to remove it can be used to locate the underground utility. See the next section for more information about hydro excavation.

Centre line locates should be provided and test holes dug where a representative of the utility identifies

- (a) alignment changes
- (b) changes in elevation.

Where an underground utility may need support or where it may shift because of disturbance of surrounding soil due to excavation, guidelines for excavation and support should be obtained from the owner of the utility (Figure 23).

### Hydro excavation —

Precautions:

- Before starting work, use barricades and signs to inform unauthorized personnel to keep out.
- Employers must ensure that workers are properly trained on the machine they are using.
- When exposing underground power utilities the operators should use bonding mats.
- Use a fall-protection system when required.
- Keep clear of the vacuum. It is powerful and can cause serious injury or even death if you are caught in the tube.
- Some utility owners set limits for the water pressure that can be used near their buried plan. Check with the utility owner before excavating.
- Excavators can refer to the following for further information:
  - TSSA/ESA *Guidelines for Excavations in the Vicinity of Gas Lines*
  - Safe Practice Guide *Excavating with Hydrovacs in the Vicinity of Underground Electrical Plant*, available from IHSA ([www.ihsa.ca](http://www.ihsa.ca)).

Workers using or in the vicinity of hydro excavation:

- Keep away from the operation if you are not directly involved in the work.
- Wear hearing protection if working in vicinity of the hydrovac truck.
- Be aware of the hazards, such as slips from the runoff water and ice during the winter.
- Wear appropriate eye and face protection such as safety glasses and faceshields. They will protect you from getting any airborne debris (caused by splashing) in your eyes.
- Keep clear of the vacuum. It is powerful and can cause serious injury or even death if you are caught in the tube.

**Breaks** — Breaks in electrical, gas, and water services can cause serious injuries, even deaths. Hitting an underground electrical line can result in electrocution, while hitting a gas line can cause an explosion. A broken water line can release a sudden rush of water, washing out support systems and causing a cave-in.

Cutting telephone lines can create a serious problem if emergency calls for police, fire, or ambulance are required.

In the event of gas line contact, call the gas company immediately. The company will check the line and close down the supply if necessary.

If a leak is suspected, people in the immediate area should be told to evacuate. Where service to a building or home has been struck, people inside should be advised to leave doors and windows open; shut off appliances, furnaces, and other sources of ignition; and vacate the premises until the gas company declares it safe to return.

Construction personnel should take two precautions.

- 1) Put out smoking materials and shut off other sources of ignition such as engines and equipment.

- 2) Leave the trench immediately. Gas can collect there.

**Overhead powerlines**

When equipment operates within reach of (and could therefore encroach on) the minimum permitted distance from a live overhead powerline, the constructor must have written procedures in place to prevent the equipment from encroaching on the minimum distance.

<b>Voltage Rating of Powerline</b>	<b>Minimum Distance</b>
750 or more volts, but not more than 150,000 volts	3 metres (10')
more than 150,000 but not more than 250,000 volts	4.5 metres (15')
more than 250,000 volts	6 metres (20')

**If equipment touches a high-voltage line, the operator should take the following precautions.**

- 1) Stay on the machine. Don't touch equipment and ground at same time. Touching anything in contact with the ground could be fatal.
- 2) Anyone operating accessory equipment should also remain on that equipment. They should also avoid making contact with the ground and the equipment at the same time.

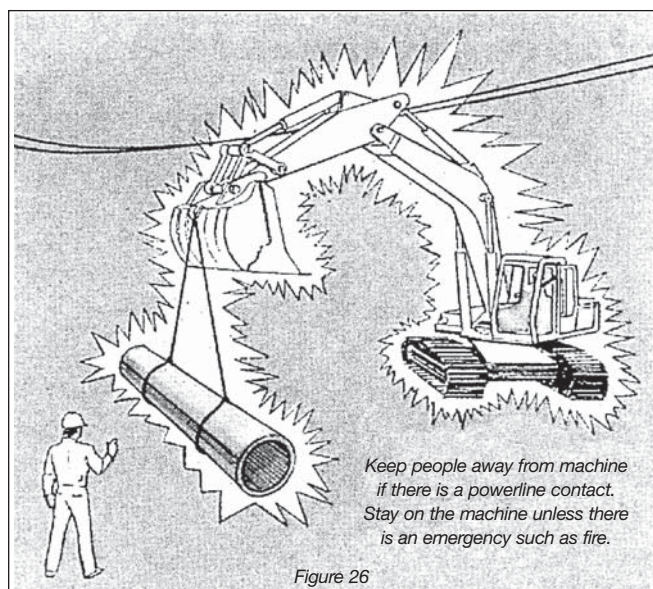
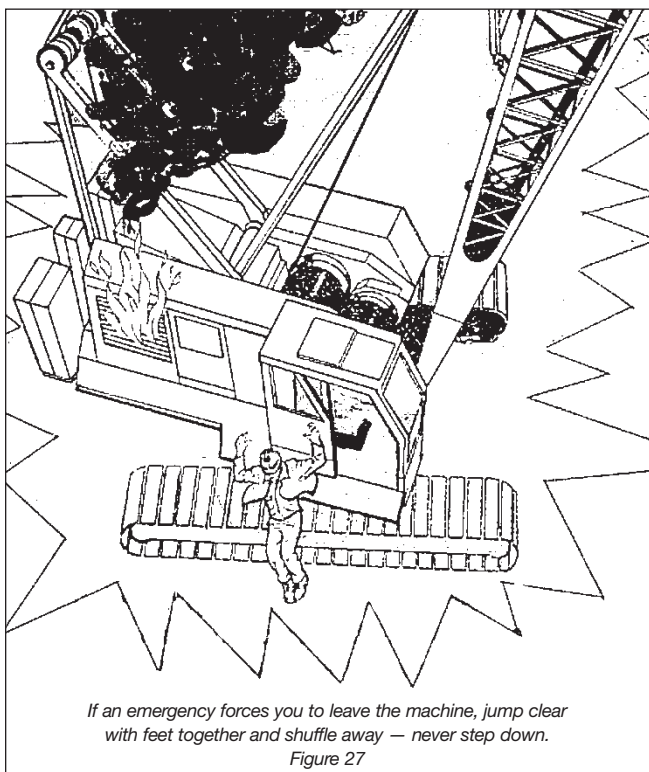

Figure 26

- 3) Keep others away. Warn them not to touch the load, load lines, boom, bucket, or any other part of the equipment (Figure 26).
- 4) Get someone to call the local utility to shut off power.
- 5) If possible, the operator (while remaining on the machine) can try to break contact by moving the machine clear of the wires.

**Warning: Beware of time relays. Even after breakers are tripped by line damage, relays may be triggered to restore power.**

- 6) If the operator can't break contact by moving the machine (while remaining on it), do not move the machine until the utility shuts down the line and confirms that power is off.
- 7) If an emergency such as fire forces you to leave the machine, jump clear (Figure 27). Never step down. If part of your body contacts the ground while another part touches the machine, current will travel through you.



- 8) Jump with feet together and shuffle away in small steps. Don't take big steps. With voltage differential across the ground, one foot may be in a higher voltage area than the other. The difference can kill you (Figure 28).

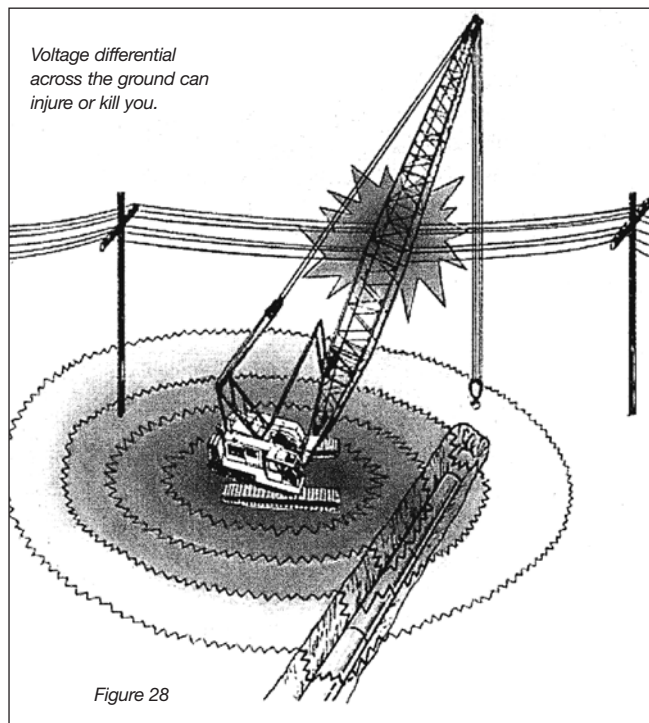

Special precautions are required for casualties in contact with live powerlines or equipment.

- 1) Never touch the casualty or anything in contact with the casualty.
- 2) If possible, break contact. Use a dry board, rubber hose, or dry polypropylene rope to move either the casualty or the line. An object can sometimes be thrown to separate the casualty from the wire.

**Warning : Touching the casualty, even with dry wood or rubber, can be dangerous. With high voltage lines, objects that are normally insulators can become conductors.**

- 3) Call emergency services — in most cases ambulance, fire department, and utility.

- 4) Provide first aid once the casualty is free of contact. If the casualty is not breathing, begin artificial respiration immediately (mouth-to-mouth is most efficient) or CPR. Apply cold water to burns and cover with clean dressing.

**Materials handling**

Many lost-time injuries in trenching involve materials handling. Moving rock and soil, lifting pipe and manhole sections, laying down bedding material, or lowering pumps and compactors into the trench can all be hazardous.

**Pipe** — Trucks should always be on level ground when pipe is unloaded. Pipe should be chocked or staked before tie-downs are released. These measures will reduce the risk of sections rolling off the truck.

Plastic and small diameter pipe is often banded with metal straps. Be careful cutting the straps. They are under tension and can fly back and hit you.

Personnel often injure fingers and hands when laying and joining sections of pipe. While sections

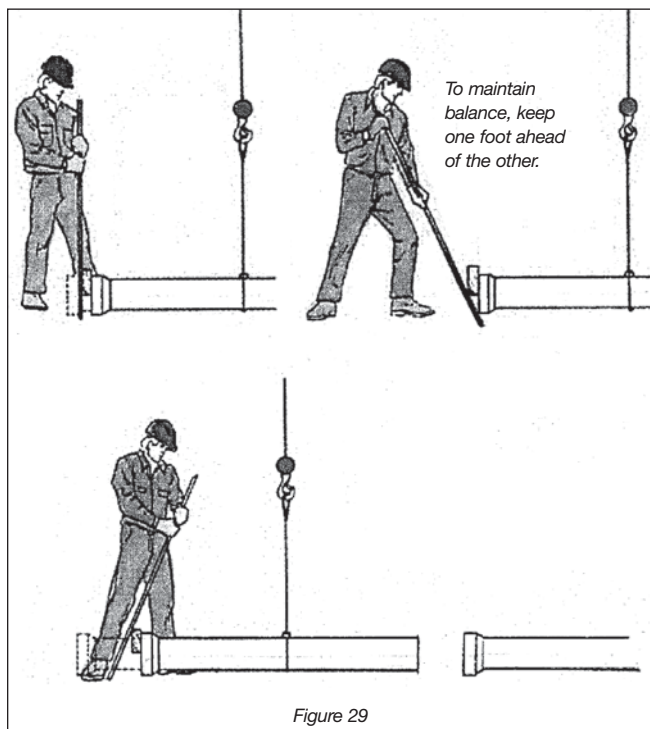

Figure 29

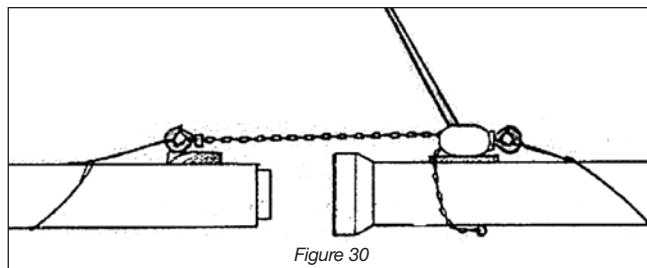

Figure 30

are suspended from hoisting equipment, keep hands away from slings or chokers in tension. When guiding and pushing sections together by hand, never curl fingers around ends or flanges.

As pipe is placed along the trench, each section should be blocked or set so that it cannot roll and cause injury.

Back injuries can occur when small-diameter pipe is being homed into position (Figure 29). The worker pushing the bar should place his feet directly in front of the pipe with one foot ahead of the other.

Large-diameter pipe should be placed with pipe pullers (Figure 30).

**Bedding material** — Personnel shovelling bedding material in the trench are usually working in a confined area where footing is muddy and uneven.

The result can be overexertion or slips and falls leading to back and other injuries. Mechanical equipment can significantly reduce this hazard. For instance, bedding material can be put in the excavator bucket with a front-end loader, then spread evenly along the trench bottom.

**Rigging** — Rigging is essential to safe, efficient materials handling since pipe, manhole sections, and equipment are lowered into the trench by cranes or other hoisting devices.

Rigging these loads properly can prevent injury.

Inspect slings and rigging hardware regularly and replace any damaged or worn devices.

With **nylon web slings**, damage is usually easy to spot: cuts, holes, tears, worn or distorted fittings, frayed material, broken stitching, heat

burns. Damaged web slings should be replaced.

When using **wire rope slings**, inspect for broken wires, worn or cracked fittings, loose seizings and splices, flattening, and corrosion. Knots or kinks indicate that wire rope slings are permanently damaged and should not be used.

Damage most often occurs around thimbles and fittings. Don't leave wire rope lying on the ground for any length of time in damp or wet conditions.

Eyes in wire rope slings should be fitted with thimbles. To make an eye with clips, put the U-bolt section on the dead or short end of the rope and the saddle on the live or long end (Figure 31). Remember — never saddle a dead horse.

At least three clips are required for wire rope up to 5/8" diameter, and four are required for wire rope greater than 5/8" up to and including 7/8" diameter.

Avoid binding the eye section of wire rope slings around corners. The bend will weaken the splice or swaging.

When using choker hitches, do not force the eye down towards the load once tension is applied.

When using **chain slings**, inspect for elongated links. A badly stretched link tends to close up (Figure 32).

Look for bent, twisted, or damaged links that can result when chain has been used to lift a

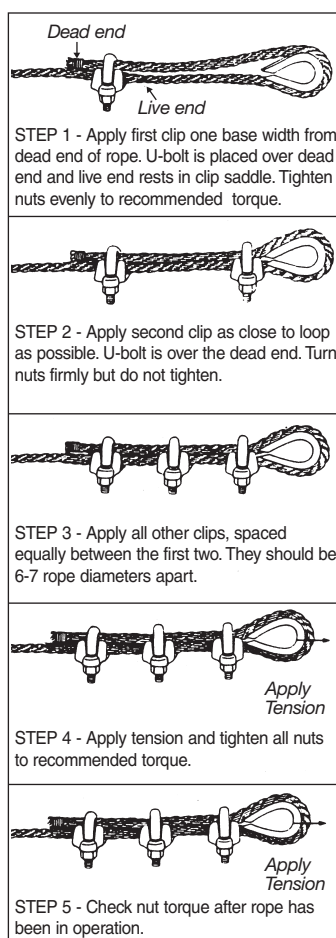

Figure 31

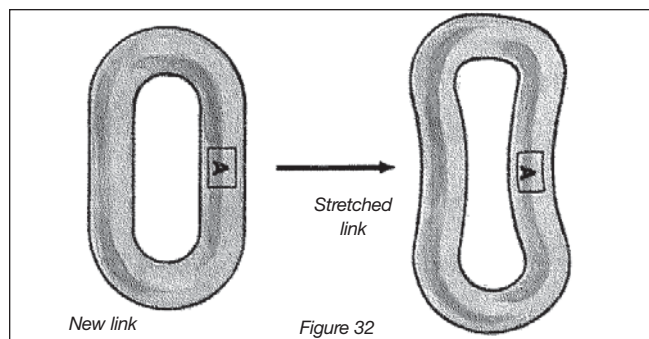

Figure 32

load with unprotected sharp edges.

Inspect for cracks. Although sometimes hard to detect, cracks always indicate that the chain should be removed from service. Also look for gouges, chips, cuts, dents, peen marks, and corrosive wear at points where links bear on each other.

### Rigging Tips

- Wherever possible, lower loads on adequate blockage to prevent damage to slings.
- Keep hands away from pinch points when slack is being taken up.
- Stand clear while the load is being lifted and lowered or when slings are being pulled out from under it.
- Use tag lines to control swinging, swaying, or other unwanted movement of the load.

### Housekeeping

Accident prevention depends on proper housekeeping at ground level and in the trench.

At the top of the trench, sections of pipe, unused tools and timber, piles of spoil, and other material must be kept at least 1 metre (3 feet) away from the edge.

The slips and falls common on excavation projects can be reduced by cleaning up scrap and debris. Trenches should also be kept as dry as possible. Pumps may be required.

Ladders should be placed within shored area and tied off to prevent slipping.

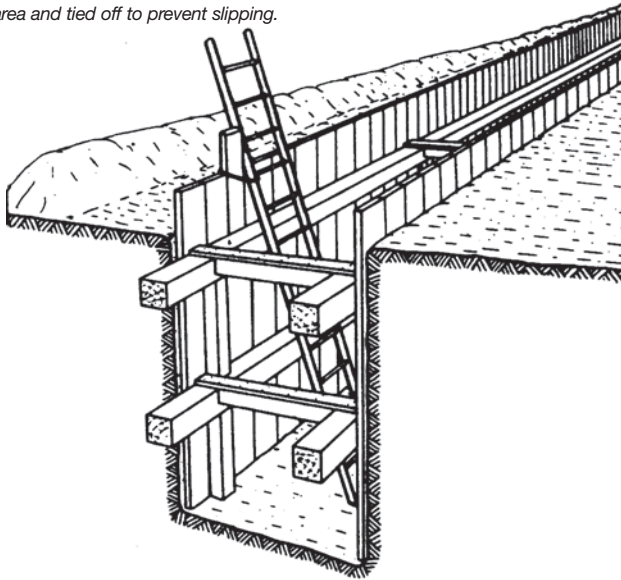

















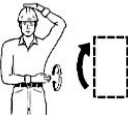





Figure 33

Proper housekeeping is especially important around ladders. The base and foot of the ladder should be free of garbage and puddles. Ladders should be tied off at the top, placed in protected areas, and inspected regularly for damage (Figure 33).

 <b>Load Up</b>	 <b>Load Down</b>	 <b>Swing Left</b>	 <b>Swing Right</b>
 <b>Turn Left</b>	 <b>Turn Right</b>	 <b>Travel</b>	 <b>This Far To Go</b>
 <b>Everything Slow</b>	 <b>Stop Engine</b>	 <b>Stop</b>	 <b>Emergency Stop</b>
 <b>Boom Up</b>	 <b>Boom Down</b>	 <b>Telescope In</b>	 <b>Telescope Out</b>
 <b>Dipper In</b>	 <b>Dipper Out</b>	 <b>Counter Rotate</b>	 <b>Counter Rotate</b>
 <b>Open Bucket</b>	 <b>Close Bucket</b>	 <b>Dog Everything</b>	<b>NO RESPONSE SHOULD BE MADE TO UNCLEAR SIGNALS</b>

### Heavy equipment

Excavators, backhoes, and other heavy equipment can cause injuries and fatalities to operators and personnel on foot.

**Excavator handsignals** — Communicate clearly with your co-workers. Use the following handsignals.

**Operators** — Improperly climbing on and off equipment has caused injuries to operators for many years. The best prevention is to maintain 3-point contact (Figure 34).

Use 3-point contact on steps and rails.

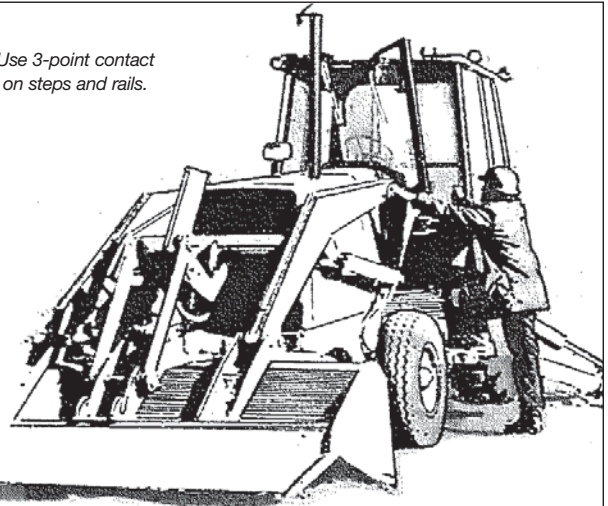

Figure 34

Equipment should be fitted with steps, grabs, and rails that are repaired or replaced when damaged.

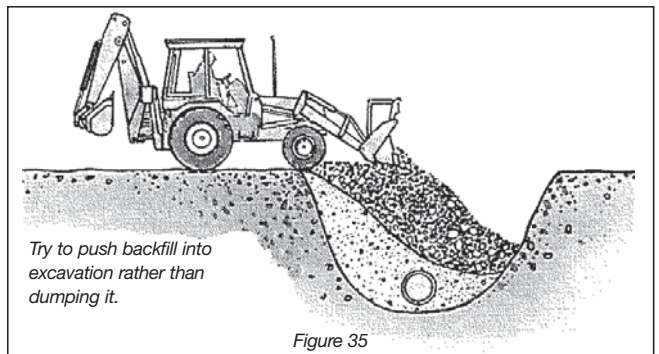

Figure 35

Operators have also suffered serious injuries when equipment upsets because of soil failure near excavations (Figure 35), improper loading on floats, or inadvertently backing into excavations.



**Moving equipment** — Signallers are required by law

- if the operator's view of the intended path of travel is obstructed, or
- if a person could be endangered by the moving equipment or its load.

Back-up alarms are required on dump trucks and recommended for all moving equipment. Where vehicles have to operate in reverse, warning signs must be conspicuously posted.

#### Ground rules for truck drivers

- Understand and obey the signaller at all times.
- Remain in the cab where possible.
- Ensure that mirrors are clean, functional, and properly adjusted.
- Do a circle check after being away from the truck for any length of time (walk around the truck to ensure the area is clear before moving).
- Stop immediately when a signaller, worker, or anyone else disappears from view.

**Workers on foot** — Personnel on foot are frequently stuck by machine attachments such as excavator buckets and bulldozer blades when they stand or work too close to operating equipment, especially during unloading and excavation.

Workers on foot are also injured and killed by equipment backing up.

#### Ground rules for workers on foot

- Beware of common operator blind spots. See chapter on Backing Up in this manual.
- Stay alert to the location of equipment around you.
- Avoid entering or standing in blind spots.
- **Always remain visible to the operator.**

**Make eye contact to ensure that you are seen.**

- Never stand behind a backing vehicle.
- Remember — the operator may be able to see you while you are standing but not when you kneel down or bend over.

**Signallers** — In heavily travelled or congested work areas, a signaller may be necessary to direct equipment and prevent injuries and deaths caused by vehicles backing up.

#### Ground rules for signallers

- Wear a fluorescent or bright orange safety vest.
- Use standard hand signals (Figure 37).
- Stand where you can see and be seen.
- Stay in full view of the operator and the intended path of travel.
- Know where the operator's blind spots are.
- Warn other workers to stay clear of equipment.

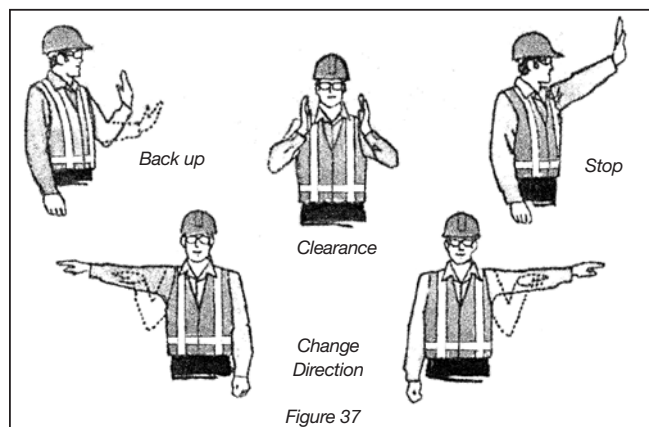

#### Traffic control

On trenching projects along public roadways, the construction crew must be protected from traffic. Regulations specify the following methods for protecting personnel:

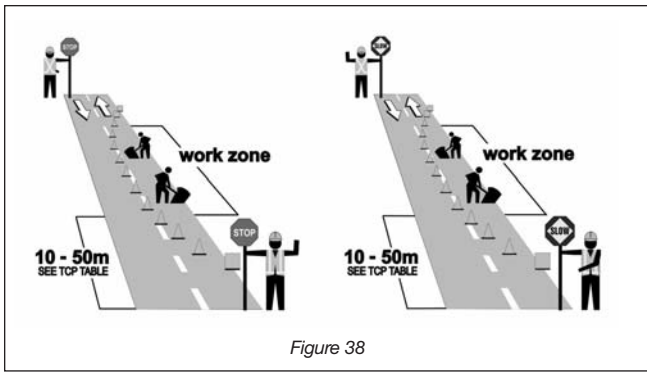

Figure 38

- traffic control persons (TCPs) using signs (Figure 38)
- warning signs
- barriers
- lane control devices
- flashing lights or flares.

Supervisors must train TCPs on site and explain the nature of the project, where construction equipment will be operating, and how public traffic will flow. TCPs must wear a fluorescent or bright orange safety vest.

Training must also include the proper use of the STOP/SLOW sign, where to stand, how to signal, and communication with other TCPs. (See chapter on Traffic Control in this manual.)

After presenting this information, the supervisors must give TCPs written instructions in a language they can understand.

**Confined spaces**

A confined space is defined as a place

- a) that is **partially or fully enclosed**
- b) that is not both designed and constructed for **continuous human occupancy**, and
- c) where **atmospheric hazards** may occur because of its construction, location, or contents, or because of work that is done in it.

All three criteria have to be met before a space is defined as a confined space.

In the sewer and watermain industry, confined spaces can be locations such as excavations, manholes, valve chambers, pump stations, and catch basins. The atmosphere in these spaces may be

- toxic
- oxygen-deficient
- oxygen-enriched
- explosive.

Sewage not only smells bad but can create dangerous atmospheres. Decaying waste releases hazardous gases such as hydrogen sulfide and methane. The bacteria in sewage are not only a source of infection but can also consume oxygen and leave the atmosphere oxygen-deficient.

Other sources of contamination can include

- fumes from welding or patching compounds
- chemicals from waste disposal sites
- engine exhaust
- propane or other explosive gases that are heavier than air and collect in the bottom of the trench
- leaks from underground storage tanks
- decomposing material in landfill sites.

Protecting the health and safety of personnel starts with some basic steps.

- A competent worker must test a confined space to determine whether it is hazard-free before a worker enters, and continue testing to ensure that it remains hazard-free.
- Where tests indicate safe air quality, workers may be allowed to enter the confined space.
- Where tests indicate a hazardous level of

fumes, vapours, gases, or oxygen, entry must not be allowed until the space has been adequately ventilated and subsequent tests indicate that the air is safe to breathe.

- Where possible, mechanical venting should be continued in any confined space containing hazardous levels of fumes, vapours, gases, or oxygen, even after venting has corrected the hazard. The space must also be continuously monitored while personnel are working there.
- In situations where ventilation has removed a hazard, workers entering the space should still wear rescue harnesses attached to individual lifelines. A worker should also be posted at the entrance prepared, equipped, and trained to provide rescue in an emergency. For rescue situations, workers entering the space should wear supplied-air respirators (Figure 40).

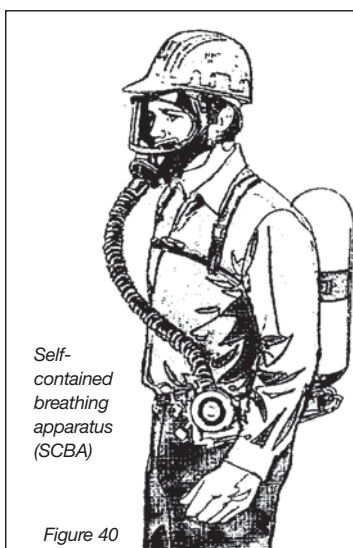

For more information on confined spaces and controls, see the chapter on Confined Spaces in this manual.

### Hydrostatic testing

Hydrostatic testing involves entry into a confined space such as a manhole or valve chamber. The procedures listed above should be followed.

Testing new lines can be very hazardous if components break or plugs let go. For that reason, additional precautions are required.

When testing watermains, ensure that all lines, elbows, and valves are supported and equipped

with thrust blocks. Otherwise the line could come apart under test pressure.

Arrange watermain testing so that lines are pressurized when no one is in the manhole or valve chamber.

For sewer line testing, all requirements for entering confined spaces apply.

Ensure that plugs are secure. No one should be in a manhole when the upstream line is being filled. Plugs that are not properly installed can let go, causing injury and letting a manhole fill quickly, depending on the size of the line.

Flooding is another reason why no one should be in a manhole without a rescue harness and a worker outside ready and prepared for an emergency.

## Emergency Procedures

### General

Emergency telephone numbers — ambulance, fire, police, local utilities, senior management, Ministry of Labour — should be posted in the field office for quick reference.

If someone is seriously injured, take the following steps.

- 1) Protect the area from hazards.
- 2) Prevent further injury to the casualty.
- 3) Administer first aid.
- 4) Call an ambulance or rescue unit.
- 5) Have someone direct the ambulance or rescue unit to the accident scene.

All projects must have a person qualified and certified to provide first aid.

### Cave-ins

It is natural to try to rescue casualties caught or buried by a cave-in. But care must be taken to prevent injury and death to rescuers, whether from a further cave-in or other hazards.

The following procedures may be suitable, depending on conditions.

- 1) To get down to the casualty, use a tarpaulin, fencing, plywood, or similar material that can cover the ground and will ride up over any further cave-in.
- 2) Sometimes a further cave-in can be prevented by placing a backhoe bucket against the suspected area or excavating it.
- 3) Rescue workers should enter the trench with ropes and wear rescue harnesses if possible.
- 4) To prevent further injury, remove the casualty by stretcher whenever possible. Tarps or ladders can be used as a makeshift stretcher.
- 5) Stabilize the casualty.

**Breathing** — Ensure that the casualty is breathing. If not, open the airway and start artificial respiration immediately. Mouth-to-mouth is the most efficient method.

**Bleeding** — Control external bleeding by applying direct pressure, placing the casualty in a comfortable position, and elevating the injured part if possible.

**Unconsciousness** — This is a priority because it may lead to breathing problems. An unconscious person may suffocate when left lying face up. If injuries permit, unconscious persons who must be left unattended should be placed in the recovery position (Figure 41).

